

# TRÉNING



FIRST OFFICER

Série FOUGA



Šroubek s gravurou letadla  
a zámkem proti protáčení

Pant s vakuem proti tření

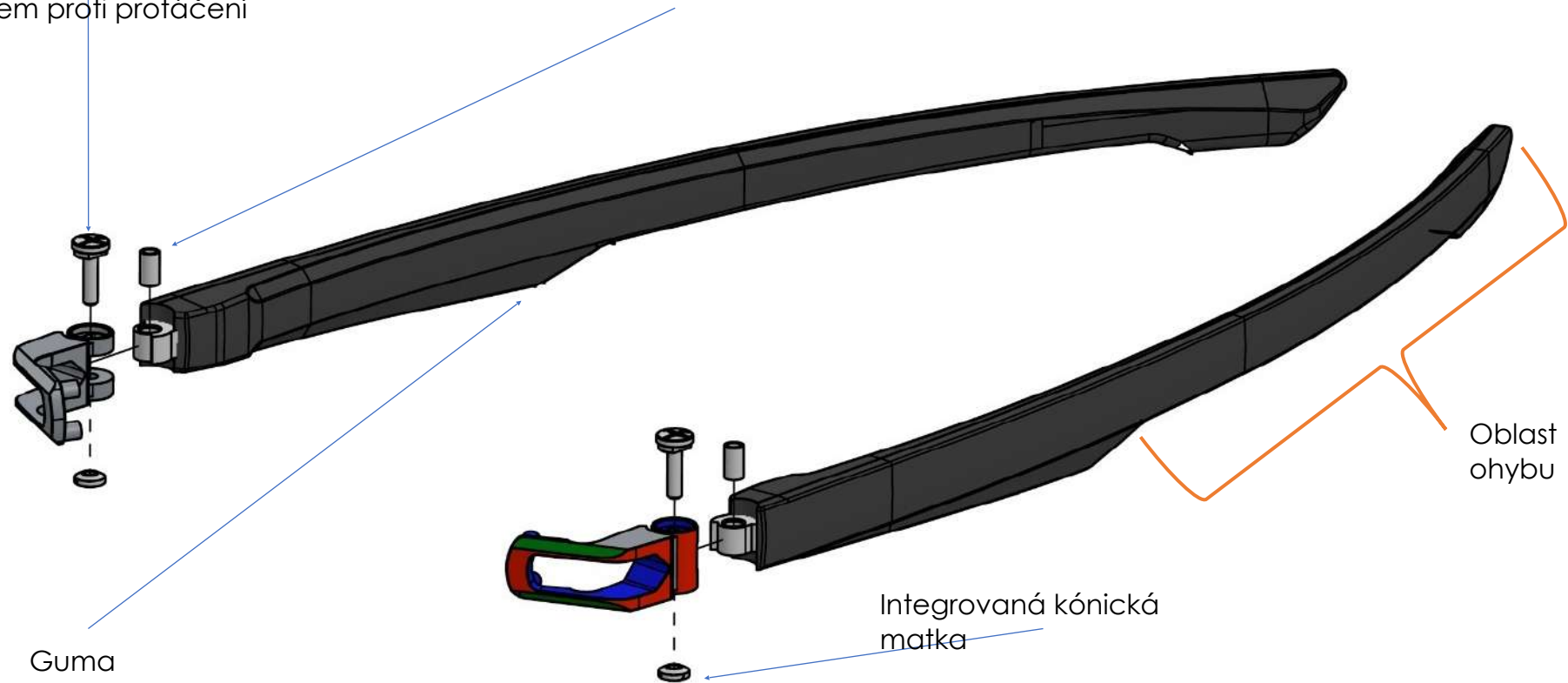

Guma

Integrovaná kónická  
matka

Oblast  
ohybu

#### Regulovaný vakuový pant:

Mezi šroubkem bez závitů a pouzdrem pantu je vakuum,  
které zajišťuje plynulé otvírání a zavírání stranice.

#### Samozamykací šroubek s gravurou:

Speciální na míru vyráběný šroubek se  
samozamykacím systémem zajišťuje, že hlavička  
šroubku je fixována stále ve stejné poloze a  
gravura letadla "Fouga" stále míří dopředu.

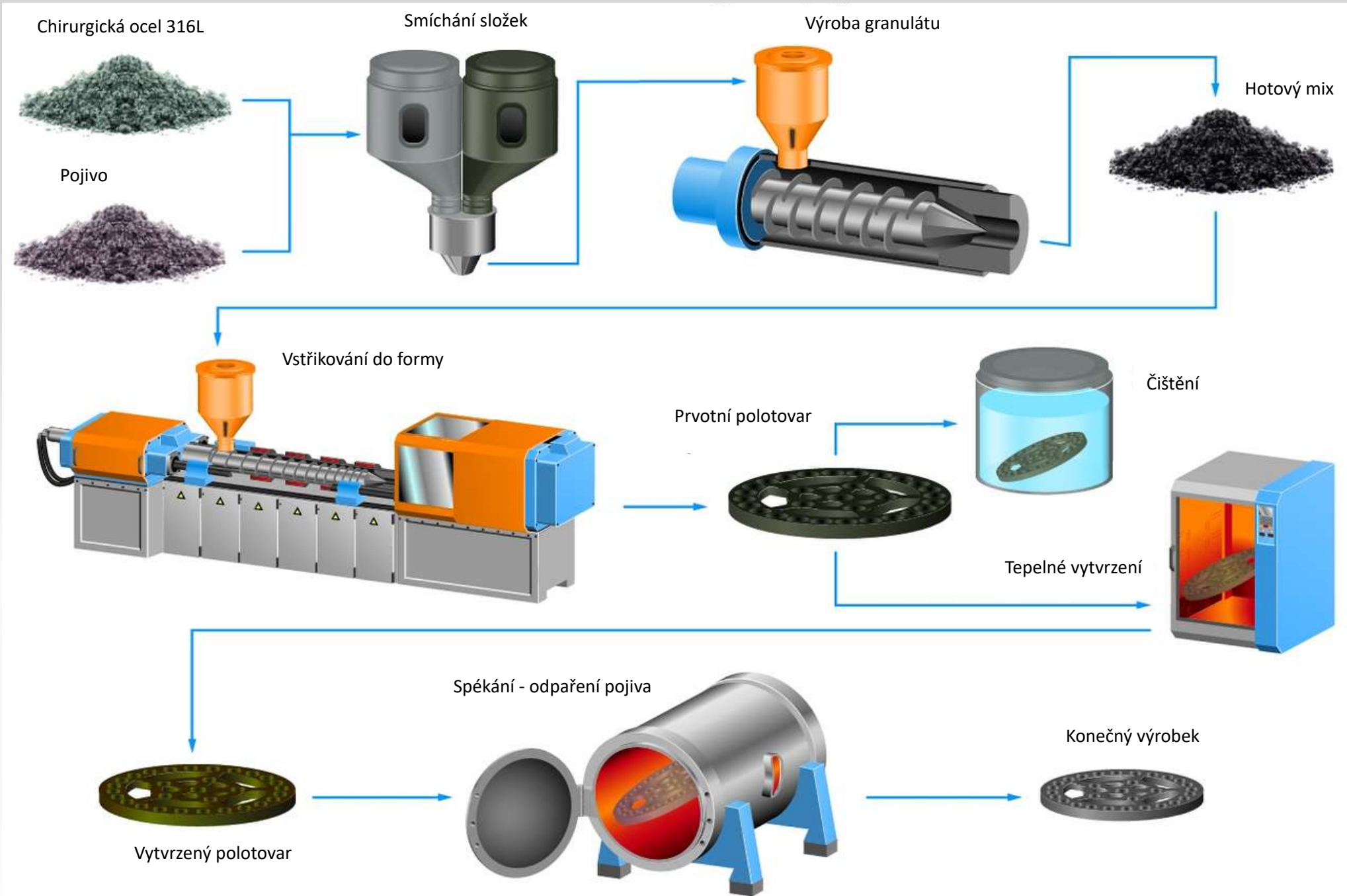

Gumové stranice:

- Specifická technologie - méně porézní materiál z Itálie
- Uvnitř drátek z oceli (Ocel 87% + 0,4% karbon + 11% chrom)
- Stěžečka z chirurgické oceli 316L vyráběná vstřikováním prášku

Nesmí se :

- Zahřívat
- Chemicky čistit
- Přizpůsobovat stěžečka

Umožňuje :

- Čištění vodou a mýdlem
- Přizpůsobovat v zúžené části
- 45° ohnutí za ucho



- Montáž:

Šroubek se přes matku zašroubuje do pouzdra. Po utažení se přebývající délka včetně hlavičky ustříhne. Náhradní šroubky jsou k dispozici.

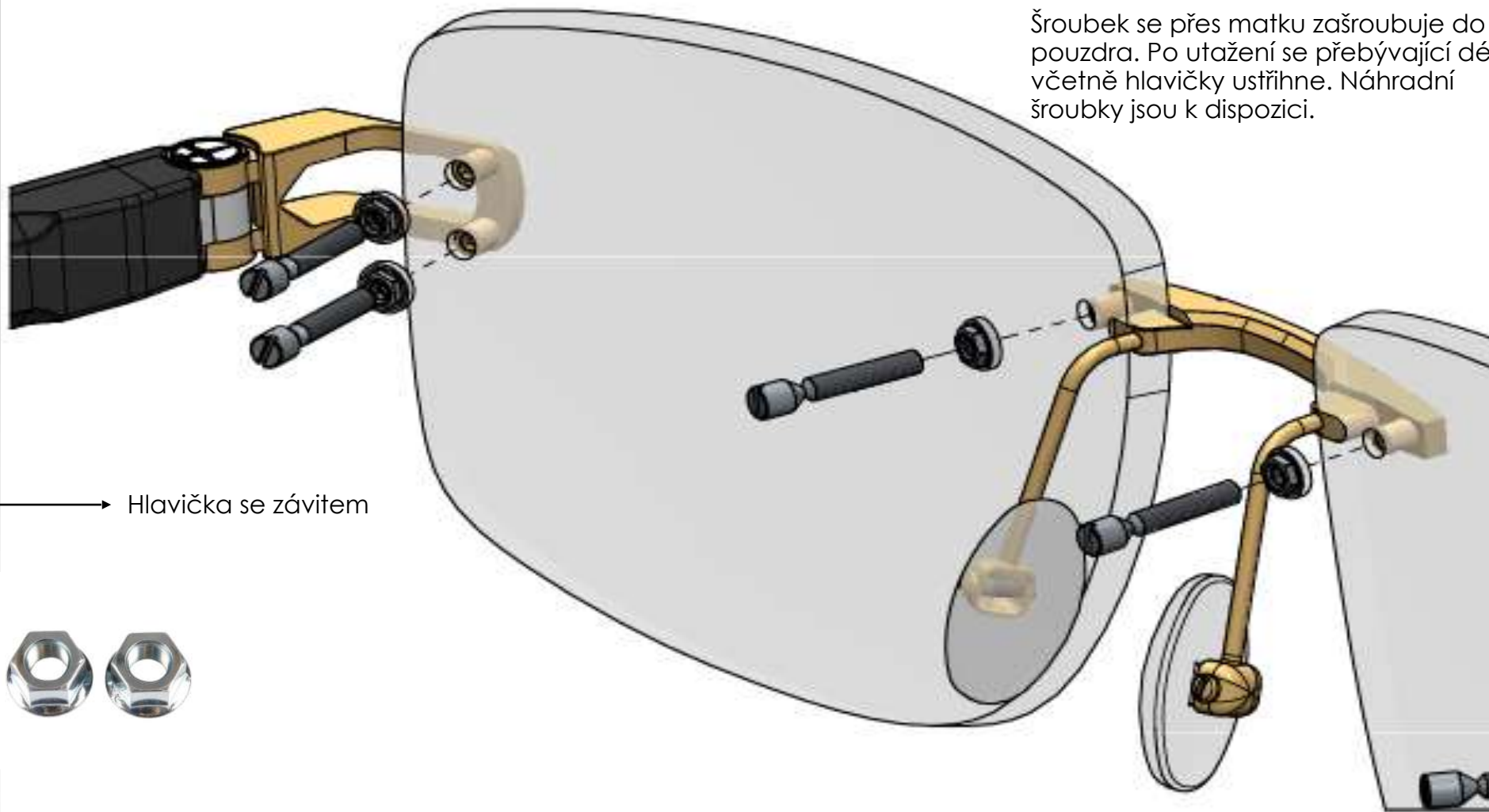

Hlavička se závitem



Pojivo uvnitř šroubku - něco mezi lepidlem a gelem, uvolní se při dotahování šroubku

# TRAINING



FIRST OFFICER

Série JET A1

9 300 RUB

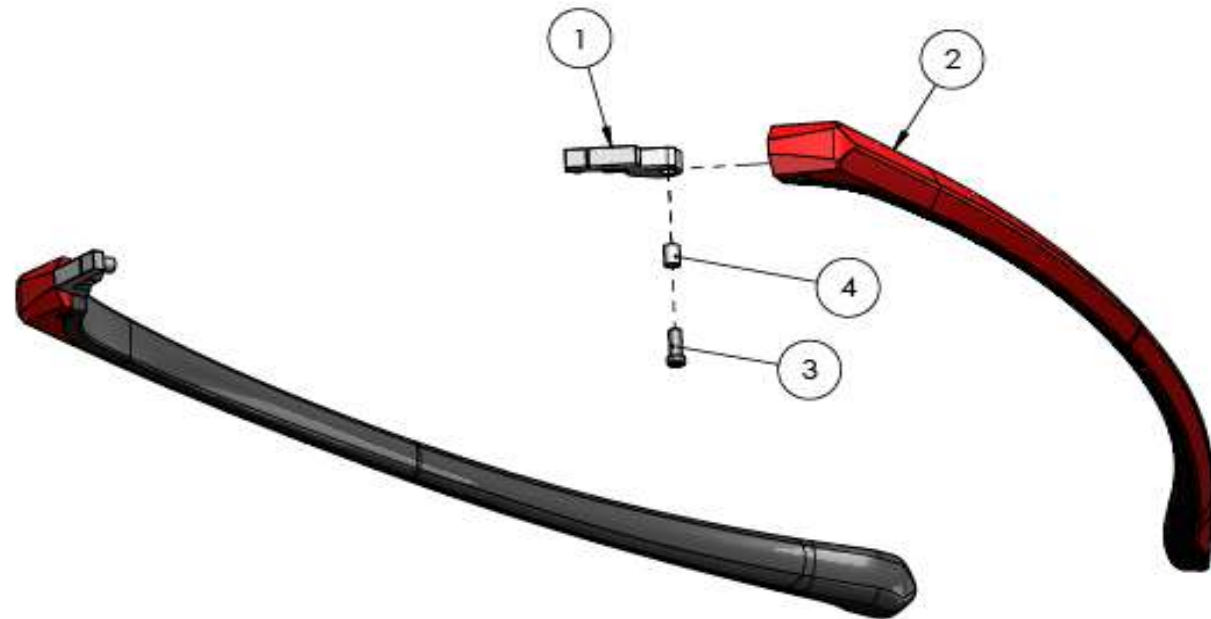

1 MIM stěžejka

2 Gumové stranice

3 Samozamykací šroubek

4 Regulovaný vakuový pant



Integrované  
pouzdro na šroubek



Integrated logo  
letadla

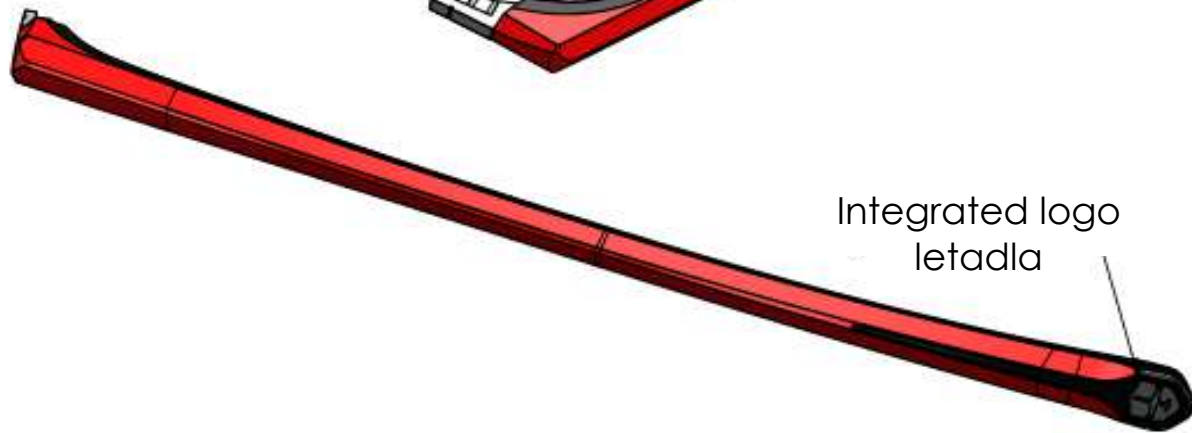



Přizpůsobovací oblast

IN049-00

CH089-00

- Vyztužení ocelovým drátkem (Ocel 87% + 0,4% karbon + 11% chrome)
- Zapuštěné logo letadla



Gumové stranice:

- Specifická technologie - méně porézní materiál z Itálie
- Uvnitř drátek z oceli (Ocel 87% + 0,4% karbon + 11% chrom)
- Stěžečka z chirurgické oceli 316L vyráběná vstříkovaním prášku

Nesmí se:

- Zahřívát
- Chemicky čistit
- Přizpůsobovat stěžečka

Umožňuje:

- Čištění vodou a mýdlem
- Přizpůsobovat v zúžené části
- 45° ohnutí za ucho



# TRAINING



FIRST OFFICER



•Série DVOJITÝ NOSNÍK



Vrtané brýle z oceli

Propracovaná ocelová hrazdička



Vrtané brýle z oceli

Flex

Spojení materiálů šroubkem

Koncovka ze zploštěného acetátu

Vtavené logo letadla pod vrstvou laku

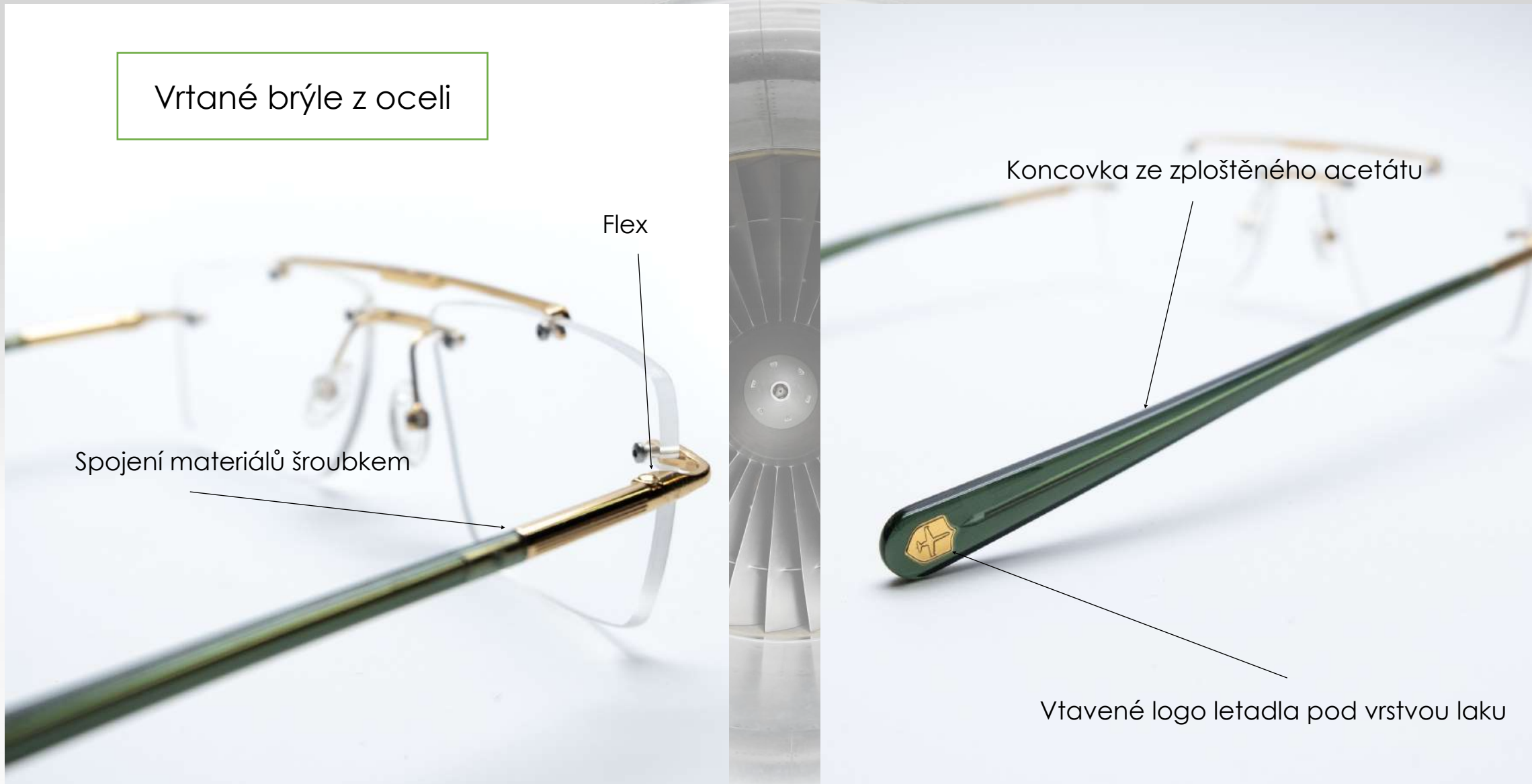

## Vrtané brýle z oceli



Galvanizace, leštění a lakování



Silikonová sedla

Vrtané brýle z oceli



Příšroubované acetátové koncovky

Integrovaný flex

Vyztužení ocelovým drátkem

Logo z oceli vsazené do acetátu a přelakované





# TRAINING



## FIRST OFFICER



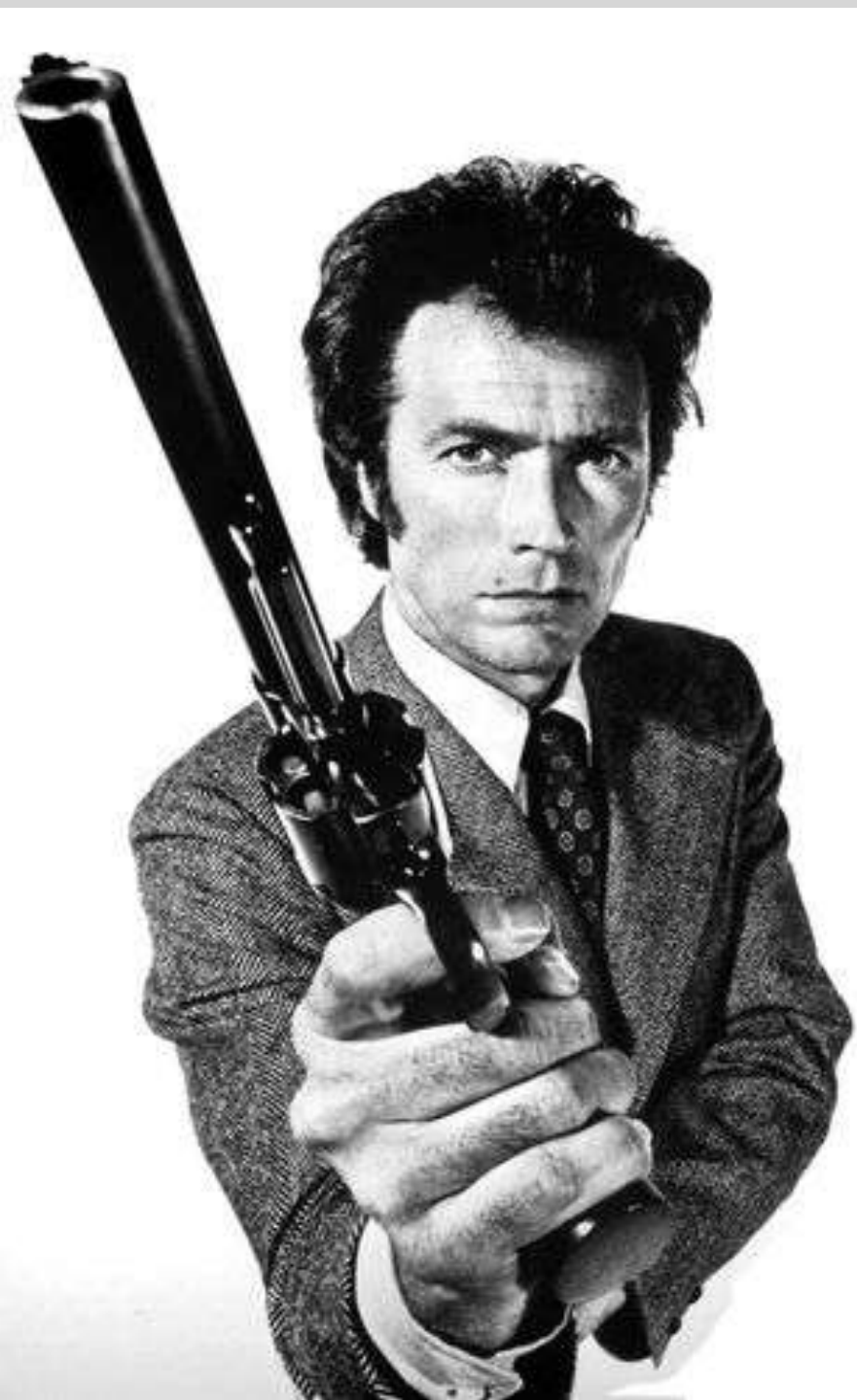

# CÍLENÍ !

First Officer je francouzská značka vyráběná v oblasti Jura - pohoří na hranici se Švýcarskem. Vychází vstříc požadavkům klientů, kteří postrádají takovýto druh produktu. Představuje jedinečné know-how v oblasti inovací technologií a designu.

First Officer je inspirován designem značky, která opustila trh již před 7 lety.

First Officer upoutá nejnáročnější klientelu, která ocení vysokou kvalitu a technické provedení. Vhodné je obrubu kombinovat se sofistikovanou třídou brýlových čoček.



NOVINKY



Perfektní  
zpracování



Perfektní  
zpracování



FIRST OFFICER

*Everywhere for every man*



Stěžeжка na míru



Kovová stěžeжка ukrytá v gumě



Jedinečný design poloobrub



Kovová stěžeжка ukrytá v gumě



Nastavitelná sedla

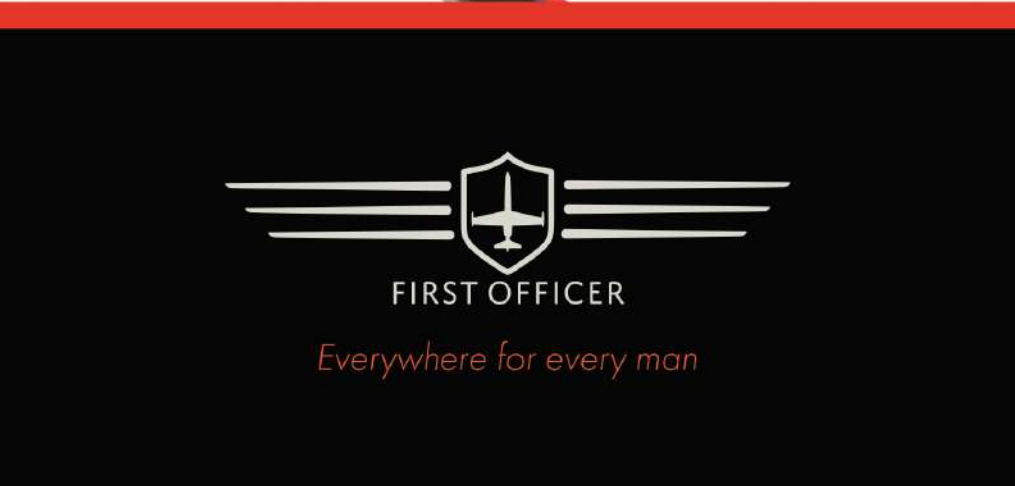

FIRST OFFICER

*Everywhere for every man*



NOVINKY



FIRST OFFICER

*Everywhere for every man*



Sluneční brýle určené i pro  
dioptrickou korekci



**VISION 180°**



Očnice ze silonu o tloušťce  
3mm s tvrzením proti  
poškrábání a zrcadlovou  
úpravou. Čočky zabroušeny na  
stříškovou fazetu nikoliv drážku.



Stěžeňka vsazená do  
gumové stranice



Specifická silikonová  
sedýlka jsou nastavitelná.





NOVINKY  
PODZIM 2023



*Everywhere for every man*



Nový koncept JT 50



Participation au concours Silmo D'or 2022  
JT 50 - Section DESIGN

Očnice z ocelového monobloku

Lehčí než vrtané brýle

Široké zorné pole



JT 50 = 25gr



FOUGA = 29gr



Skrytá ocelová stěžejka jako u JET A1



Skryté šroubování očnice

FIRST



Nastavitelná  
sedla



Vsazené ocelové logo  
letadla



Laserové  
gravírování  
nosníku

Zkosená frézovaná  
hrana očnice



Everywhere for every man



FIRST OFFICER

*Everywhere for every man*



FIRST OFFICER

